

BANDIT AIR SCREEN

ITEM: _____ QUANTITY: _____

MODEL # SCRFC

SCRFC - Shown with standard features.

SPECIFICATIONS

The SCRFC is a metal framed base refrigerated self-service display case with a choice of standard grade plastic laminate exterior ends. Unique design allows zero clearance from wall.



- Available depths: 32 3/8"
- Available lengths: 36" 48" 60" 72"
- Available heights: 60" 78"

STANDARD FEATURES

- Self-Contained Refrigeration
- Metal Framed Base with Black Louvered Air Grill
- Brushed Aluminum Interior Ends
- Standard Grade Laminate Exterior with T Mold Edge
- Stainless Steel Deck (Hemmed to Contain Spills)
- Stainless Steel Perforated Back Panel
- Front Air Intake - Top Air Discharge — Zero Clearance
- Top Canopy Light
- 2 Stainless Steel Shelves (60" High)
- 4 Stainless Steel Shelves (72" High)
- UL Listed in Accordance with NSF 7
- (2) 115V/60/Single Phase Circuits Required on 3'0" Unit
- 115V/208-230V/60/Single Phase for 4'0", 5'0", 6'0"
- Thermometer

WHEN ORDERING, PLEASE SPECIFY:

APPLICATION: _____

REFRIGERATION TYPE: _____

LAMINATE COLOR: _____

OPTIONAL FEATURES

- Stainless Steel Exterior Finish with Standard T-molding
- Special Laminates
- Wood Veneers (Unfinished)
- Wood Veneers (Stained & Sealed)
- Lights Under Shelves
- Promolux Lighting (Low UV)
- Wire Shelves: Brass White Black Chrome
- Casters
- Bullet Feet
- Powder Coated Interior Back Panel and Hardware:
 - Black White Custom Color
- Stainless Steel Mirrored Polished Interior Ends
- Stainless Steel Mirrored Polished Interior Back
- Finished Back with Black Air Grill
- Stainless Steel Louvered Air Grill
- Rear Sliding Doors - Solid
- Rear Sliding Doors - See-Through
- Removable Locking Security Panels
- Extra Large Heavy Duty Condensate Evaporation Pan
- Pull Down Econo Night Shade
- #23 Econo Frost Night Shade
- Tie In Strips for Interconnection of Units
- 5 Year Compressor Warranty

BANDIT AIR SCREEN

TOLL FREE: 800-525-3692

MODEL # SCRFC

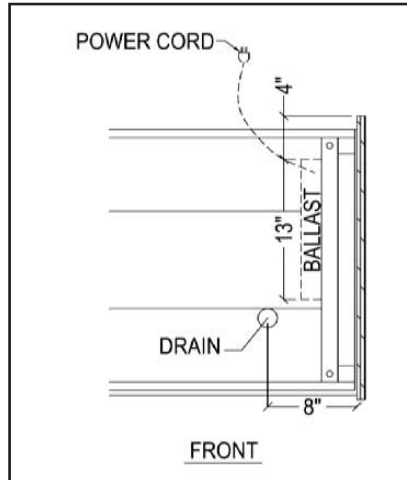
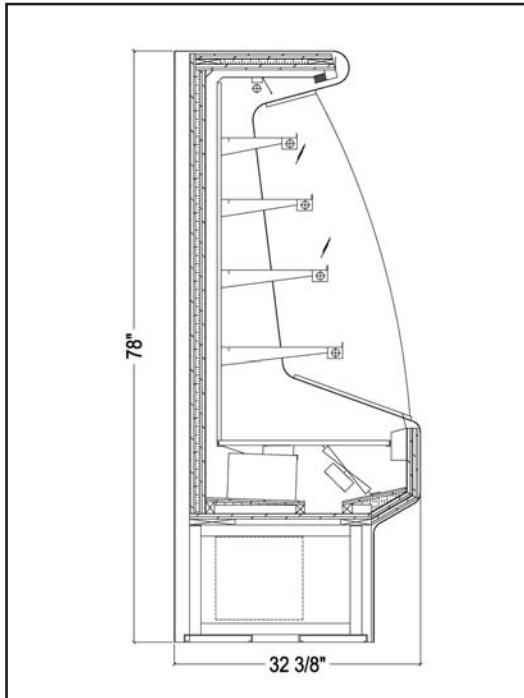

NOTE: A minimum of 12" clearance needed above unit for air discharge for self contained units.



Electrical & Plumbing locations

Refrigerated Case Display 67C9 Listed
Also classified by Underwriters Laboratories Inc.
In Accordance with ANSI/NSF 7-1999 and ANSI/NSF 2-1999

NOTE: Due to horsepower requirements, noise levels can reach 75 DB"s. Please verify location. Tile floors, low ceilings, small rooms or multiple self-contained units will elevate the noise level. Remote refrigeration is recommended.

MODEL	L	D	H	COMP HP	VOLT	AMP	NEMA PLUG	WT
SCRFC3660R	36	32 3/8	60	1/2	(2)115V	11.0/8.3	(2) 5-15P	575
SCRFC4860R	48	32 3/8	60	3/4	115/208-230	13.7	L14-20P	675
SCRFC6060R	60	32 3/8	60	1	115/208-230	17.2	L14-30P	775
SCRFC7260R	72	32 3/8	60	1	115/208-230	17.8	L14-30P	875
SCRFC3678R	36	32 3/8	78	1/2	(2)115V	11.5/8.3	(2) 5-15P	625
SCRFC4878R	48	32 3/8	78	3/4	115/208-230	14.2	L14-20P	700
SCRFC6078R	60	32 3/8	78	1	115/208-230	17.7	L14-30P	825
SCRFC7278R	72	32 3/8	78	1	115/208-230	18.5	L14-30P	950

The 3 ft. unit requires 2 circuits. Total Amps for the 4, 5 & 6 ft. units includes 4.8 Amps for the condensate evaporator.

The SCRFC merchandiser is designed for use in stores where temperature and humidity do not exceed 75° F. and 55% R.H. Locate away from direct sunlight, rapid air currents and extreme temperature changes. Exposure to air currents from ceiling fans, air conditioners, ovens, etc. will disrupt the case's air curtain and refrigerated zone. Any adverse conditions will affect warranty.

RPI in line with it's policy to continually improve it's product reserves the right to change materials and specifications without notice.

CALL TOLL FREE: 800-525-3692 (609-714-2330)

FAX: 609-714-2331 www.regalpinnacl.com

220 ROUTE 70, MEDFORD, NJ 08055

RPI REGAL PINNACLE INTEGRATIONS INDUSTRIES, INC.