

# BRAVO AIR SCREEN

ITEM: \_\_\_\_\_ QUANTITY: \_\_\_\_\_

## MODEL # SCRFC

SCRFC - Shown with standard features.

### SPECIFICATIONS

The SCRFC Bravo series is a metal framed base refrigerated self-service display case with a choice of standard grade plastic laminate exterior ends. Unique design allows zero clearance from wall.



Available depths:  32 3/8"

Available lengths:  36"  48"  60"  72"

### STANDARD FEATURES

- Self-Contained Refrigeration
- Metal Framed Base with Black Louvered Air Grill
- Brushed Aluminum Interior Ends
- Perforated Stainless Back Panel
- Standard Grade Laminate Exterior with T Mold Edge
- Stainless Steel Removable Deck Pan - Hemmed to Contain Spills
- UL Listed in Accordance with NSF 7
- (2) 115V Circuits Required for 3' and 4' units  
115V/208-230V/60/Single Phase for 5' and 6' units (Neutral Wire Required)
- 134A Refrigerant 3' and 4' units
- R-22 Refrigerant 5' and 6' units
- Thermometer

### OPTIONAL FEATURES

- Stainless Steel Exterior Finish with Standard T Molding
- Special Laminates
- Wood Veneers (Unfinished)
- Wood Veneers (Stained & Sealed)
- Miscellaneous Trim
- Top Canopy Light
- Promolux Light (Low UV)
- Casters
- Bullet Feet
- Powder Coated Interior Back Panel and Hardware:  
 Black  White  Custom Color
- Stainless Steel Mirrored Polished Interior Ends
- Pull Down Econo Night Shade
- Stainless Steel Front Grill
- #23 Econo Frost Night Shade
- Removable Locking Security Panel
- Extra Large Heavy Duty Condensate Evaporation Pan
- Stainless Steel Step Sham
- Black Styrene Step Sham
- Cord and Plug
- 5 Year Compressor Warranty
- Finished Back with Black Air Grill

### WHEN ORDERING, PLEASE SPECIFY:

APPLICATION: \_\_\_\_\_

\_\_\_\_\_

REFRIGERATION TYPE: \_\_\_\_\_

\_\_\_\_\_

LAMINATE COLOR: \_\_\_\_\_

\_\_\_\_\_

# BRAVO AIR SCREEN

TOLL FREE: 800-525-3692

## MODEL # SCRFC

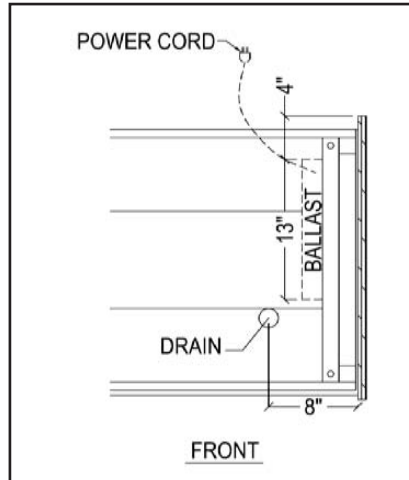
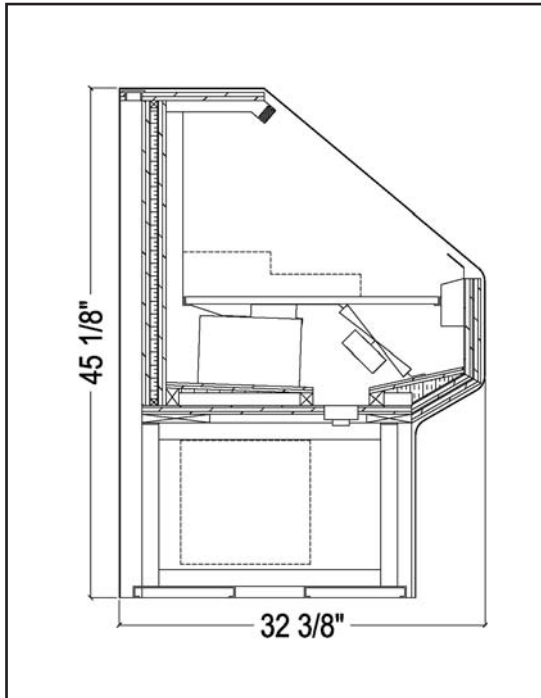

### Electrical & Plumbing locations

Refrigerated Case Display 67C9 Listed  
Also classified by Underwriters Laboratories Inc.  
In Accordance with ANSI/NSF 7-1999 and ANSI/NSF 2-1999

**NOTE:** Due to horsepower requirements, noise levels can reach 75 DB's. Please verify location. Tile floors, low ceilings, small rooms or multiple self-contained units will elevate the noise level. Remote refrigeration is recommended.

MODEL	L	D	H	COMP HP	VOLT	AMP	NEMA PLUG	WT
SCRFC3648R	36	32 3/8	45 1/8	1/2	(2)115V	10.4/8.3	(2)5-15P	360
SCRFC4848R	48	32 3/8	45 1/8	1/2	(2)115V	10.4/8.3	(2)5-15P	450
SCRFC6048R	60	32 3/8	45 1/8	3/4	115/208-230	13.4	L14-20P	540
SCRFC7248R	72	32 3/8	45 1/8	3/4	115/208 -230	13.8	L14-20P	630

The 3 ft. unit requires 2 circuits. Total Amps for the 4, 5 & 6 ft. units includes 4.8 Amps for the condensate evaporator.

The SCRFC merchandiser is designed for use in stores where temperature and humidity do not exceed 75 degrees F and 55% R. H. Locate away from direct sunlight, rapid air currents and extreme temperature changes. Exposure to air currents from ceiling fans, air conditioners, ovens, etc. will disrupt the case's air curtain and refrigerated zone within. Any adverse conditions will affect warranty.

RPI in line with it's policy to continually improve it's product reserves the right to change materials and specifications without notice.

CALL TOLL FREE: 800-525-3692 (609-714-2330)

FAX: 609-714-2331 [www.regalpinnacle.com](http://www.regalpinnacle.com)

220 ROUTE 70, MEDFORD, NJ 08055

**RPI** REGAL  
PINNACLE  
INTEGRATIONS INDUSTRIES, INC.