

# ANDOVER BAKERY

ITEM: \_\_\_\_\_ QUANTITY: \_\_\_\_\_

## WITH LIFT FRONT GLASS MODEL # SCDB-II

### SPECIFICATIONS

The SCDB-II is a Bakery display case with a choice of standard grade plastic laminate exterior ends and curved lift-up tempered glass. Available refrigerated or non-refrigerated.

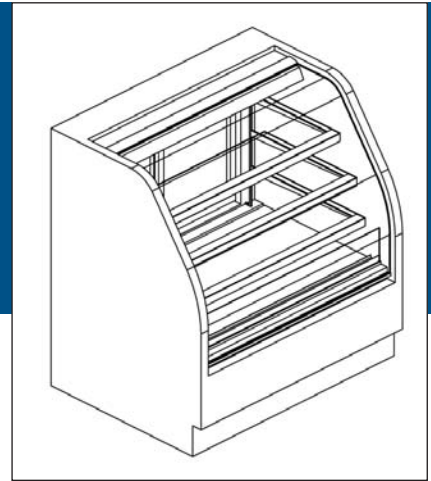

Available depths:  35 3/4"

Available lengths:  48"  60"  72"  94 1/8"

### STANDARD FEATURES

- Standard Grade Laminate Exterior
- Top Canopy Light
- 3 Tempered Glass Shelves with Lights
- White Laminated Deck
- Mirrored Interior Ends
- Mirrored Rear Sliding Doors
- 115V/60/Single Phase
- UL Listed in Accordance with NSF 7
- Built-In Condensate Evaporator
- 134A Refrigerant
- Black Base
- Thermometer

### OPTIONAL FEATURES

- Stainless Steel Exterior Finish
- Special Laminates
- Stainless Steel Deck
- Wood Veneers (Unfinished)
- Wood Veneers (Stained & Sealed)
- Miscellaneous Trim
- Promolux Lighting (Low UV)
- Brass Trim and Hardware
- Wire Shelves
  - Brass  White  Black  Chrome
- Casters
- Bullet Feet
- Rear Fold Down Work Ledge
- Rear Door Locks
- Front Glass Locks
- 5 Year Compressor Warranty
- Remote Refrigeration

### WHEN ORDERING, PLEASE SPECIFY:

APPLICATION: \_\_\_\_\_

REFRIGERATION TYPE: \_\_\_\_\_

LAMINATE COLOR: \_\_\_\_\_

# ANDOVER BAKERY

TOLL FREE: 800-525-3692

## WITH LIFT FRONT GLASS MODEL # SCDB-II

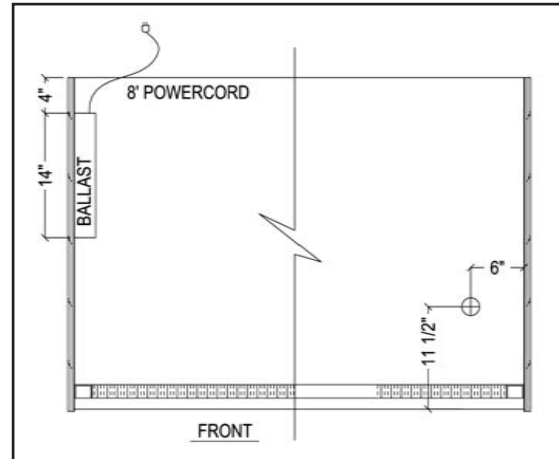
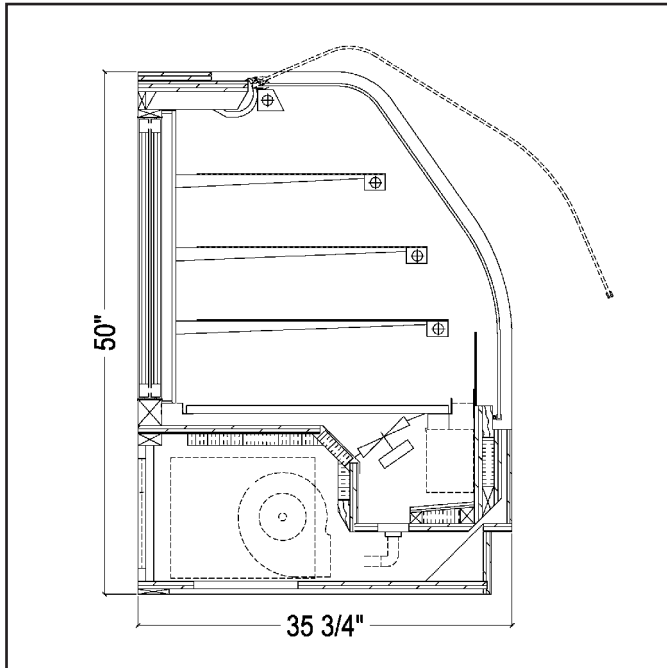

### Electrical & Plumbing locations



Refrigerated Case Display 67C9 Listed  
Also classified by Underwriters Laboratories Inc.  
In Accordance with ANSI/NSF 7-1999 and ANSI/NSF 2-1999

MODEL	L	D	H	COMP HP	VOLT	AMP	NEMA PLUG	WT
SCDB48R-II	48	35 3/4	50	1/3	115V	11.5	5-15P	650
SCDB60R-II	60	35 3/4	50	1/3	115V	11.5	5-15P	750
SCDB72R-II	72	35 3/4	50	1/2	115V	14.5	5-20P	1000
SCDB96R-II	94 1/8	35 3/4	50	1/2	115V	15.6	5-20P	1100
SCDB48D-II	48	35 3/4	50		115V	1.2	5-15P	450
SCDB60D-II	60	35 3/4	50		115V	1.2	5-15P	550
SCDB72D-II	72	35 3/4	50		115V	1.8	5-15P	700
SCDB96D-II	94 1/8	35 3/4	50		115V	2.2	5-15P	875

The SCDB-II merchandiser is designed for use in stores where temperature and humidity do not exceed 75 degrees F and 55% R.H. Locate away from direct sunlight, rapid air currents and extreme temperature changes. Any adverse conditions will affect warranty.

RPI in line with it's policy to continually improve it's product reserves the right to change materials and specifications without notice.

CALL TOLL FREE: 800-525-3692 (609-714-2330)

FAX: 609-714-2331 [www.regalpinnacl.com](http://www.regalpinnacl.com)

220 ROUTE 70, MEDFORD, NJ 08055

**RPI** REGAL PINNACLE INTEGRATIONS INDUSTRIES, INC.